

Pièces de rechange

Spare parts list

Roto

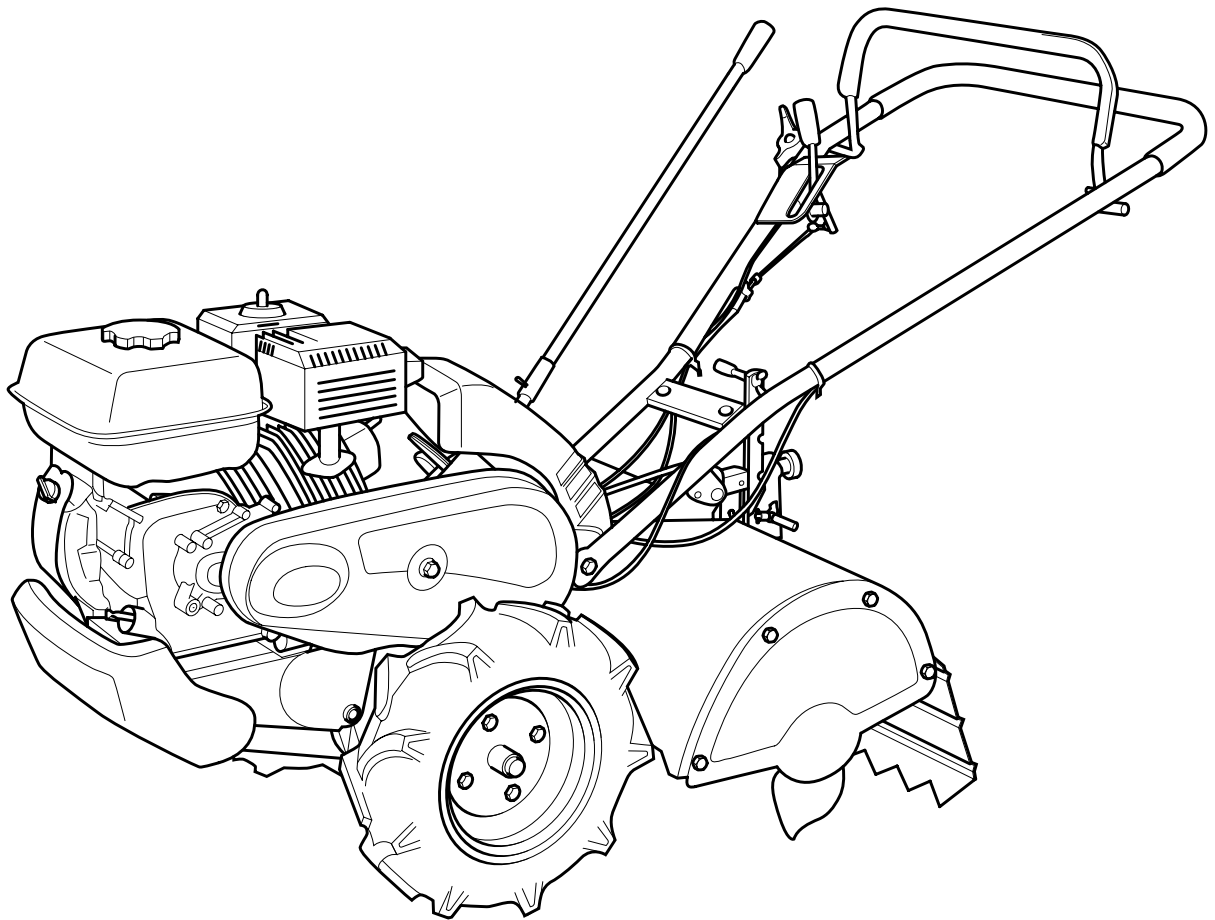

MONTAGE MOTEUR ENGINE CONSTRUCTION

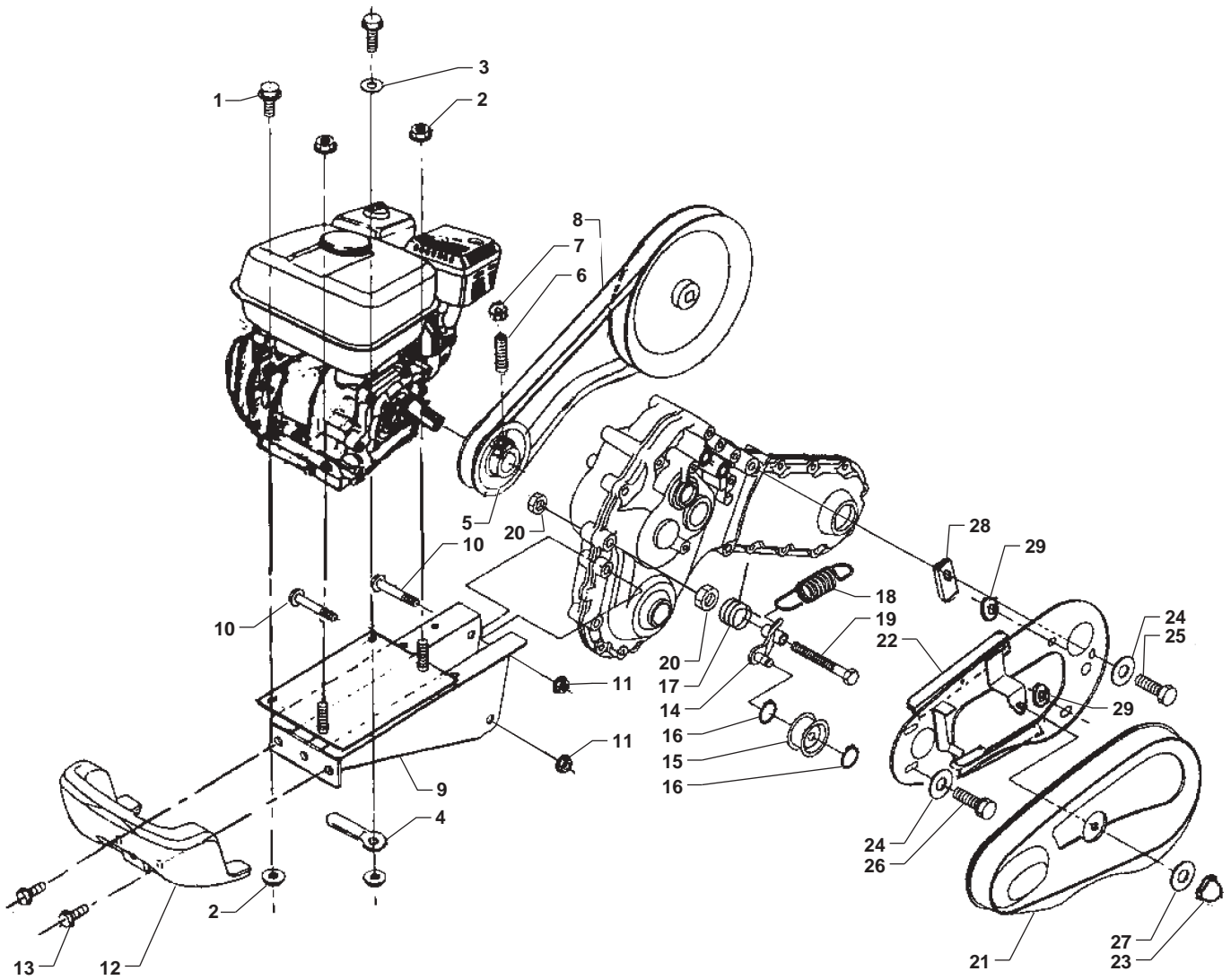

Rep N°	Ref.	Rq Rk	Désignation	Description	Qté Qty
1	F050 0108 035		Vis M8 x 35	BOLT flange M8 x 35	2
2	F301 0108 000		Écrou M8	NUT flange M8	4
3	0350 0140 818		Rondelle M8	WASHER M8	1
4	0050 2108 083		Crampon L=80	CLAMP L=80	1
5	P506 0201 000		POULIE	V-PULLEY 70	1
6	03650-50814		Vis M8	SET SCREWS M8	1
7	A301 0108 003		Écrou M8	NUT M8	1
8	0852 1500 037		Courroie SB37	V-BELT SB37	1
9	P506 2301 000		Chassis	ENGINE FRAME	1
10	F050 0110 060		Vis M10 x 60	BOLT flange M10 x 60	2
11	F301 0110 000		Écrou M10	NUT flange M10	2
12	1490 2352 000		Contre poids	BALANCE WEIGHT	1
13	F050 0110 030		Vis M10 x 30	BOLT flange M10 x 30	2
14	1490 1516 000		Support galet tendeur	ARM	1
15	3610 1506 000		Galet tendeur	PULLEY tight	1
16	0740 0001 200		Circlips ø12	C-RING ø12	2
17	1429 1508 000		RESSORT	SPRING	1
18	1425 1509 000		RESSORT	SPRING	1
19	1421 1511 000		VIS	BOLT	1
20	A301 0112 002		ÉCROU M12	NUT M12	2
21	1490 1551 000		CAPOT COURROIE	COVER	1
22	P506 1557 000		CACHE INTÉRIEUR	COVER	1
23	A341 0130 802		ÉCROU M8	NUT M8	1
24	0350 0130 820		RONDELLE M8	WASHER M8	5
25	A800 0108 020		VIS M8 x 16	CT-BOLT M8 x 16	3
26	F050 0108 016		VIS M8 x 16	BOLT flange M8 x 16	2
27	0350 0150 822		RONDELLE M8	WASHER M8	1
28	1490 1559 000		PLAQUE	PLATE	1
29	2701 4273 000		RONDELLE	WASHER	2

BOITE DE TRANSMISSION TRANSMISSION CASE

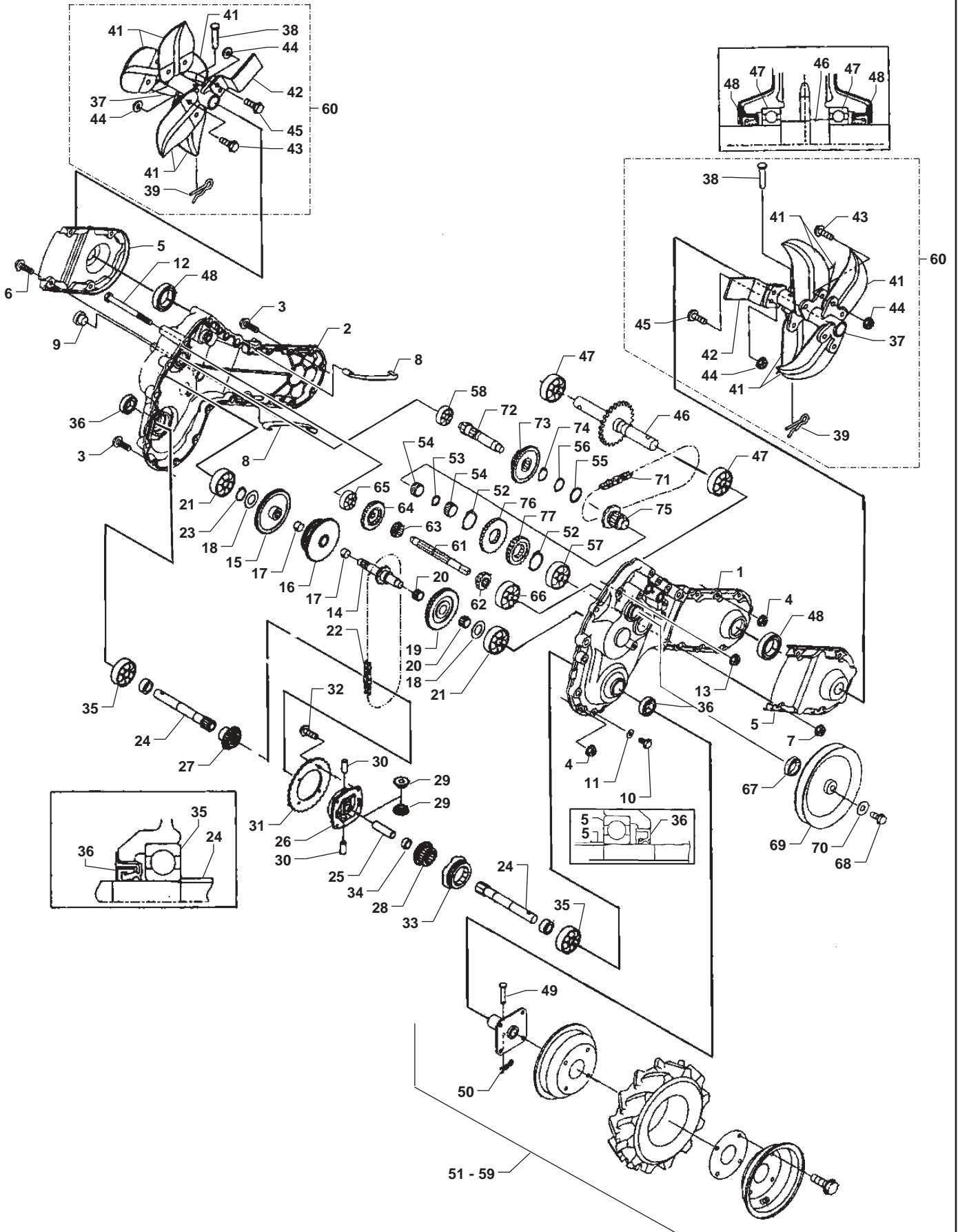

Rep N°	Ref.	Rq Rk	Désignation	Description	Qté Qty
1	1429 1005 000		Carter Gauche	CASE LA	1
2	1429 1006 000		Carter Droit	CASE RA	1
3	F050 0108 030		Vis M8 x 30	BOLT flange M8 x 30	8
4	F301 0108 000		Écrou M8	NUT flange M8	8
5	1429 1011 000		Couvercle	COVER	2
6	F050 0108 035		Vis M8 x 35	BOLT flange M8 x 35	2
7	F301 0108 000		Écrou M8	NUT flange M8	2
8	1429 101 5001		Ressort	SPRING	2
9	3150 1016 000		Bouchon d'huile	PLUG oil	1
10	2740 3214 200		Bouchon	PLUG	1
11	0833 1000 800		Rondelle M8	WASHER seal M8	1
12	A054 0108 110		Vis M8 x 110	BOLT 7T M8 x 110	2
13	F301 0108 000		Écrou M8	NUT flange M8	2
14	1429 1151 001		Axe	SHAFT 3	1
15	1429 1152 001		Pignon 50 50T	GEAR 50 50T	1
16	1429 1153 000		Pignon 36-49 36-49T	GEAR 36-49 36-49T	1
17	0797 2018 120		Bague	BUSHING	2
18	2761 3113 000		Rondelle	LINER B	2
19	1429 1156 000		Pignon 24-35 24-35T	GEAR 24-35 24-35T	1
20	1429 1159 000		Roulement	BEARING needle	2
21	0750 0062 020		Roulement 6202	BEARING ball 6202	2
22	0870 2110 400		Chaîne 40L	CHAIN 40L	1
23	0740 0001 500		Circlips ø15	C-RING ø15	1
24	1429 1252 001		Arbre de roue	FINAL SHAFT	2
25	0540 0116 063		Goupille	PIN	1
26	1429 1254 000		Renvoi d'angle	CASE diff	1
27	1429 1255 000		Pignon 22A 22T	GEAR 22A side 22T	1
28	1429 1258 000		Pignon 22B 22T	GEAR 22B side 22T	1
29	1429 1267 000		Pignon 13	PINION 13	2
30	1429 1259 000		Goupille	PIN center	2
31	1429 1266 000		Courroie 30 dents 30T	SPROCKET 30T 30T	1
32	F050 0106 012		Vis M6 x 12	BOLT flange M6 x 12	4
33	1429 1268 000		Manchon	SLEEVE	1
34	1429 1269 000		Entretoise	COLLAR	1
35	07500062040		Roulement 6204	BEARING ball 6204	2
36	2740 3624 100		Joint	SEAL oil	2
37	NON DETAILLE		Table de rotation	PIPE rotary	2
38	1924 1311 000		Axe	PIN cleves	2
39	1924 1312 000		Goupille	PIN snap	2
40	1429 1326 000		Dent compteur	TINE ASSY	1
41	1924 1317 001		Dent	TINE	10
42	1924 1318 003		Dent	TINE	2
43	NON DETAILLE		Vis M10 x 20	BOLT flange M10 x 20	20
44	NON DETAILLE		Écrou M10	NUT flange M10	24
45	F050 0110 025		Vis M10 x 25	BOLT flange M10 x 25	4
46	1428 1321 000		Arbre d'entraînement	ROTARY SHAFT	1
47	0750 0060 050		Roulement 6005	BEARING ball 6005	2
48	0841 2254 011		Joint TCFY25401	SEAL oil TCFY25401	2
49	0562 1108 040		Axe ø8 x 40	PIN clevis ø8 x 40	2
50	0521 0108 000		Goupille ø8	PIN snap ø8	2
51	1490 1371 000		Roue complète G	TIRE LH ASSY	1
52	0740 0003 500		Circlips Ø 35	C-RING Ø 35	2
53	1429 1112 001		Entretoise	COLLAR	1
54	1429 1113 000		Roulement	BEARING needle	2
55	1414 1108 000		Rondelle	LENER	1
56	0740 0002 000		Circlips Ø 20	C-RING Ø 20	1
57	0750 0063 020		Roulement 6302	BEARING ball 6302	1
58	0750 0062 020		Roulement 6202	BEARING ball 6202	1
59	1490 1381 000		Roue complète D	TIRE RH ASSY	1
60	1429 1333 000		Fraise droite ou gauche complète	TINES RIGHT OR LEFT ASSEMBLY	2
61	1429 1051 000		Axe	SHAFT 1	1
62	1429 1056 000		Pignon 14T	GEAR 14T	1
63	1429 1052 000		Pignon 14T	GEAR 14T	1
64	1429 1053 000		Pignon 31T	GEAR 31T	1
65	0750 0062 010		Roulement 6201	BEARING ball 6201	1
66	0750 0063 020		Roulement 6302	BEARING ball 6302	1
67	0840 1015 307		Joint TC 15307	SEAL oil TC 15307	1
68	F050 0108 020		Vis M8 x 20	BOLT flange M8 x 20	1
69	1490 1063 000		Poulie 171	V-PULLEY 171	1
70	0350 0160 826		Rondelle M8	WASHER M8	1
71	0870 2320 560		Chaîne	CHAIN	1
72	1429 1101 001		Axe	SHAFT	1
73	1429 1102 000		Pignon 25-41T	GEAR 25-41T	1
74	0740 0002 200		Circlips Ø 22	C-RING Ø 22	1
75	1429 1104 001		Pignon 9T	SPROCKET 9T	1
76	1429 1105 000		Pignon 31T	GEAR 31T	1
77	1429 1106 000		Pignon 23T	GEAR 23T	1

SELECTEUR CHANGE

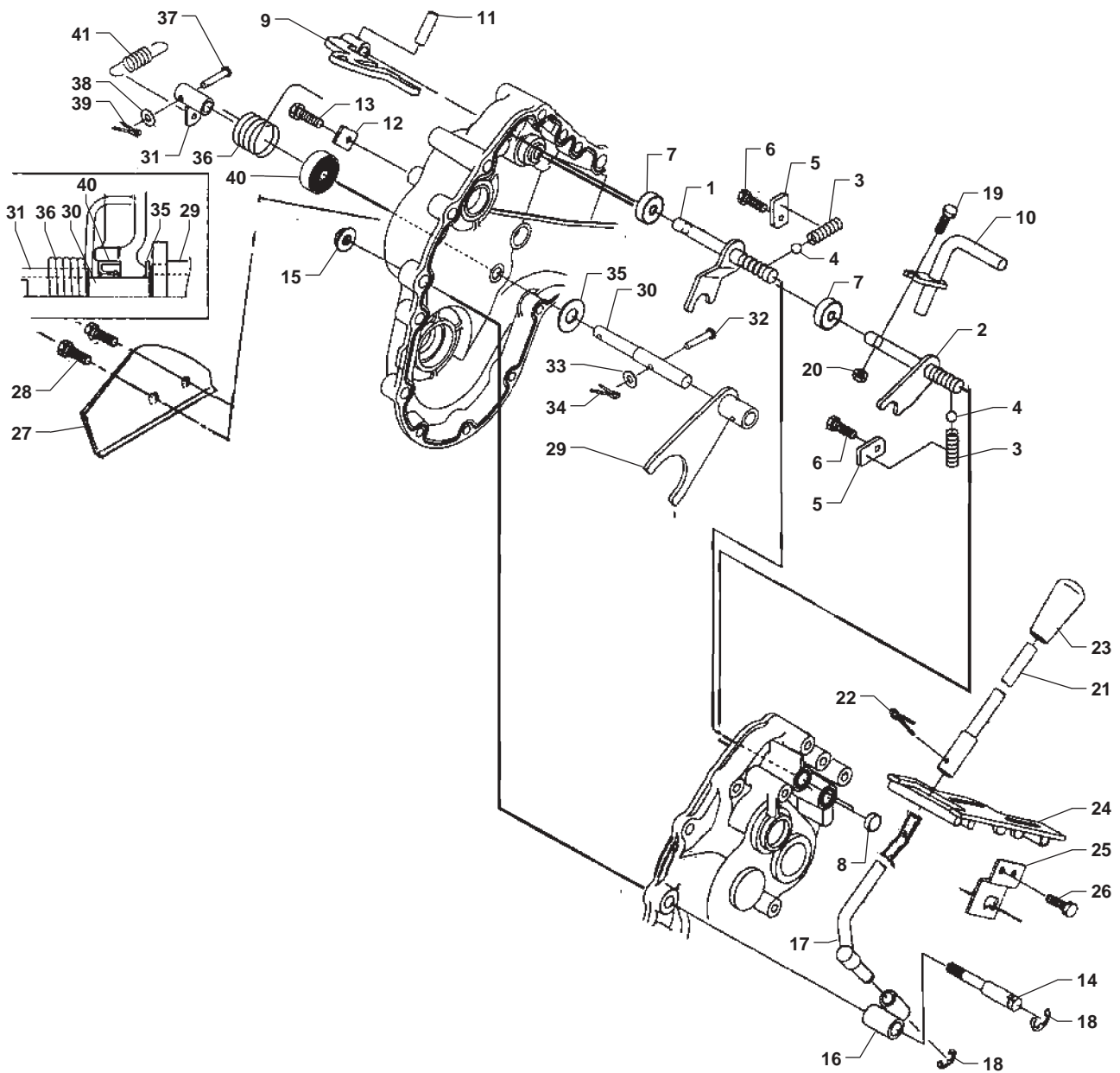
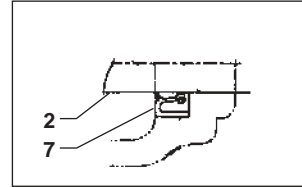
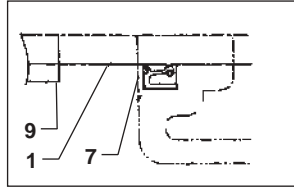

Rep N°	Ref.	Rq Rk	Désignation	Description	Qté Qty
1	1429 1401 000		Fourchette D	SHIFTER D	1
2	1429 1402 001		Fourchette G	SHIFTER R	1
3	1429 1418 000		Ressort	SPRING	2
4	0800 0000 600		BILLE 1/4"	BALL 1/4"	2
5	1429 1403 000		Patte	PLATE	2
6	A800 0106 016		Vis M6 x 16	CT-BOLT M6 x 16	2
7	0840 1012 227		JOINT TC12227	SEAL oil TC12227	2
8	0834 0020 070		Joint ø20	CAP seal ø20	2
9	14291404000		Bras A	ARM A	1
10	14291405000		Bras B	ARM B	1
11	0550 0006 025		Goupille ø6 x 25	PIN spring ø6 x 25	1
12	1429 1406 000		Plaque	PLATE	1
13	A800 0106 016		Vis M6 x 16	CT-BOLT M6 x 16	1
14	1429 1407 000		Axe	SHAFT	1
15	F301 0110 000		Écrou M10	NUT flange M10	1
16	1429 1408 000		Pièce de commande	BOSS	1
17	P506 1409 000		Levier	LEVER	1
18	7420101000		Circlips ø10	E-RING ø10	2
19	A524 0106 025		Vis	BOLT	1
20	A300 0106 002		Écrou M6	NUT M6	1
21	1490 1412 000		Levier	LEVER	1
22	0520 0125 025		Goupille ø2,5 x 25	PIN split ø2,5 x 25	1
23	0691 0012 250		Poignée	GRIP	1
24	1429 1413 000		Plaque	PLATE	1
25	1429 1416 000		Plaque	PLATE	1
26	F050 0106 016		Vis M6 x 16	BOLT flange M6 x 16	2
27	P506 1418 000		Plaque	PLATE	1
28	A800 0108 016		Vis M8 x 16	CT-BOLT M8 x 16	2
29	1429 1601 000		Fourchette	ARM	1
30	1429 1609 000		Axe	SHAFT	1
31	1429 1621 000		Sélecteur	ARM	1
32	0562 1106 030		Axe ø6 x 30	PIN clevis ø6 x 30	1
33	0350 0130 613		Rondelle M6	WASHER M6	1
34	0520 0125 012		Goupille ø2,5 x 12	PIN split ø2,5 x 12	1
35	3121 255 9000		Rondelle	LINER	1
36	1429 1626 000		Ressort	SPRING	1
37	0562 1106 025		Axe M6	PIN clevis M6	1
38	0350 0130 613		Rondelle M6	WASHER M6	1
39	0520 0125 012		Goupille ø2,5 x 12	PIN split ø2,5 x 12	1
40	0840 1012 227		Joint TC12227	SEAL oil TC12227	1
41	1425 1509 000		Ressort	SPRING	1

GUIDON HANDLE

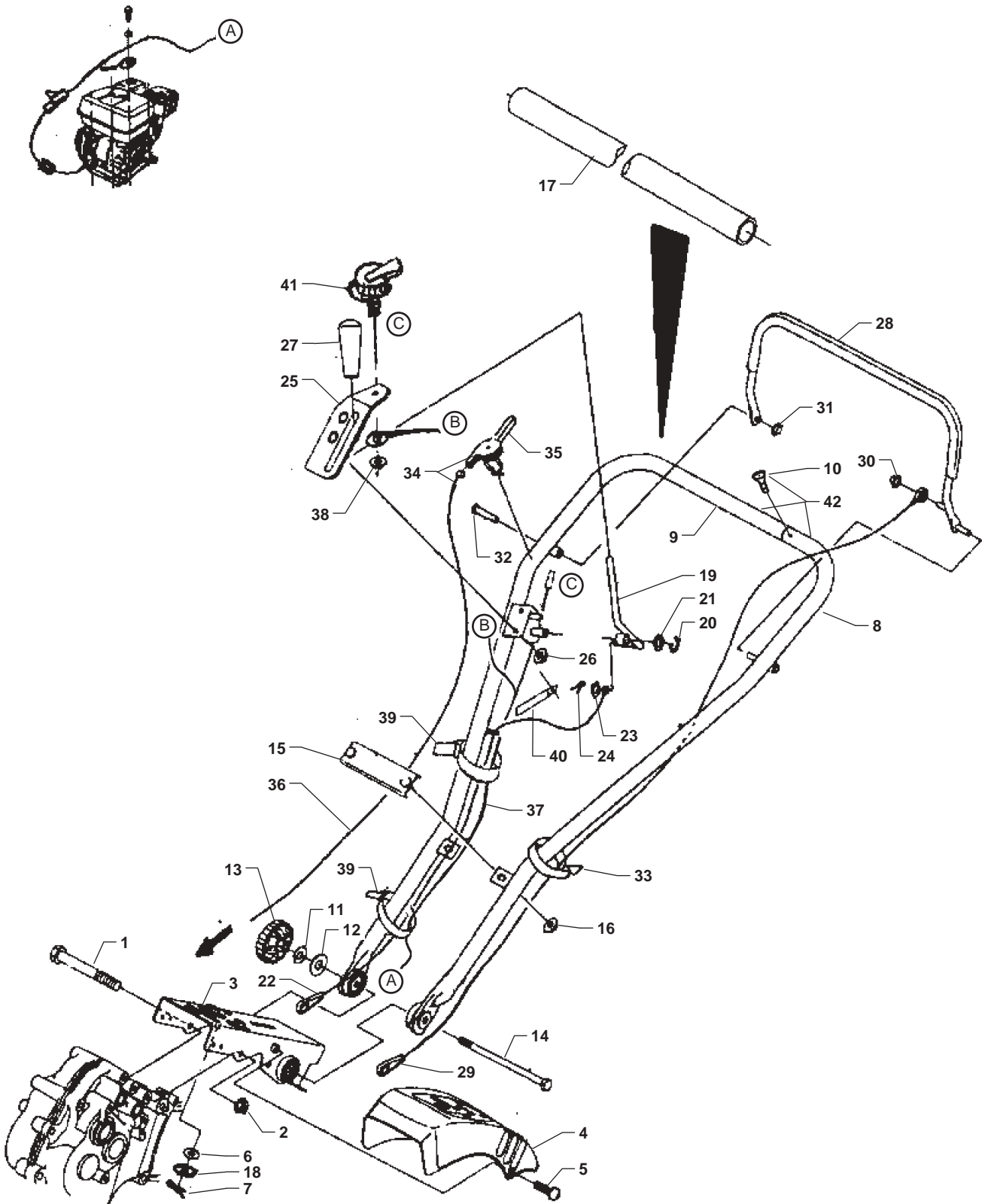

Rep N°	Ref.	Rq Rk	Désignation	Description	Qté Qty
1	A054 0108 125		Vis M8 x 125	BOLT 7T M8 x 125	2
2	F301 0108 000		Écrou M8	NUT flange M8	2
3	1429 2001 000		Tole de fixation Bras	FRAME handle	1
4	1490 2031 000		Couvercle	COVER A panel	1
5	1924 2206 000		Vis	SCREW	2
6	0350 0140 818		Rondelle M8	WASHER M8	2
7	0521 0108 000		Goupille ø8	PIN snap ø8	2
8	P506 2052 000		Demi-guidon G	HANDLE LH	1
9	P506 2053 000		Demi-guidon D	HANDLE RH	1
10	A222 0106 016		Vis	SCREW	1
11	A360 0101 002		Rondelle ressort M10	WASHER spring M10	1
12	0350 0151 026		Rondelle M10	WASHER M10	1
13	1429 2061 000		Molette	GRIP	1
14	1429 2062 000		Vis	BOLT	1
15	1429 2056 000		Patte	PLATE	1
16	F301 0108 000		Écrou M8	NUT flange M8	2
17	1924 2061 000		Poignée caoutchouc	GRIP	1
18	O833 1000 800		Rondelle	WASHER seal	2
19	149 02123 000		Levier	LEVER	1
20	0742 0100 900		Circlips ø9	E-RING ø9	1
21	0731 0101 210		Rondelle t=1.0	LINER t=1.0	1
22	P506 2121 000		Cable	WIRE	1
23	0350 0130 615		Rondelle M6	WASHER M6	1
24	0520 0125 012		Goupille ø0,25 x12	PIN slip ø0,25 x12	1
25	1429 2131 000		Couvercle	COVER	1
26	F300 0106 000		Écrou M6	NUT flange M6	2
27	0691 0010 257		Poignée	GRIP	1
28	1924 2105 001		Levier	LEVER clutch	1
29	P506 2106 000		Cable	WIRE	1
30	1924 2107 000		Écrou	CAP NUT	1
31	1924 2108 000		Écrou	CAP NUT	1
32	1924 2109 000		Axe	PIN clevis	1
33	0051 1032 070		Collier	BAND wire	1
34	P506 2158 000		Levier complet	LEVER ASSY	1
35	0687 2025 431		Levier	THROTTLE LEVER	1
36	P506 2159 000		Cable	WIRE	1
37	P506 2161 000		Câble électrique	LEAD WIRE	1
38	F301 0108 000		Écrou M8	NUT flange M8	1
39	0051 1032 070		Collier	BAND WIRE	2
40	0050 2108 063		Agraffe L=80	CLAMP L=80	1
41	P506 2165 000		SWITCH STOP	STOP SWITCH	1
42	P506 2051 000		Ensemble guidon	HANDLE	1

CARTER DE ROTATION ROTARY COVER

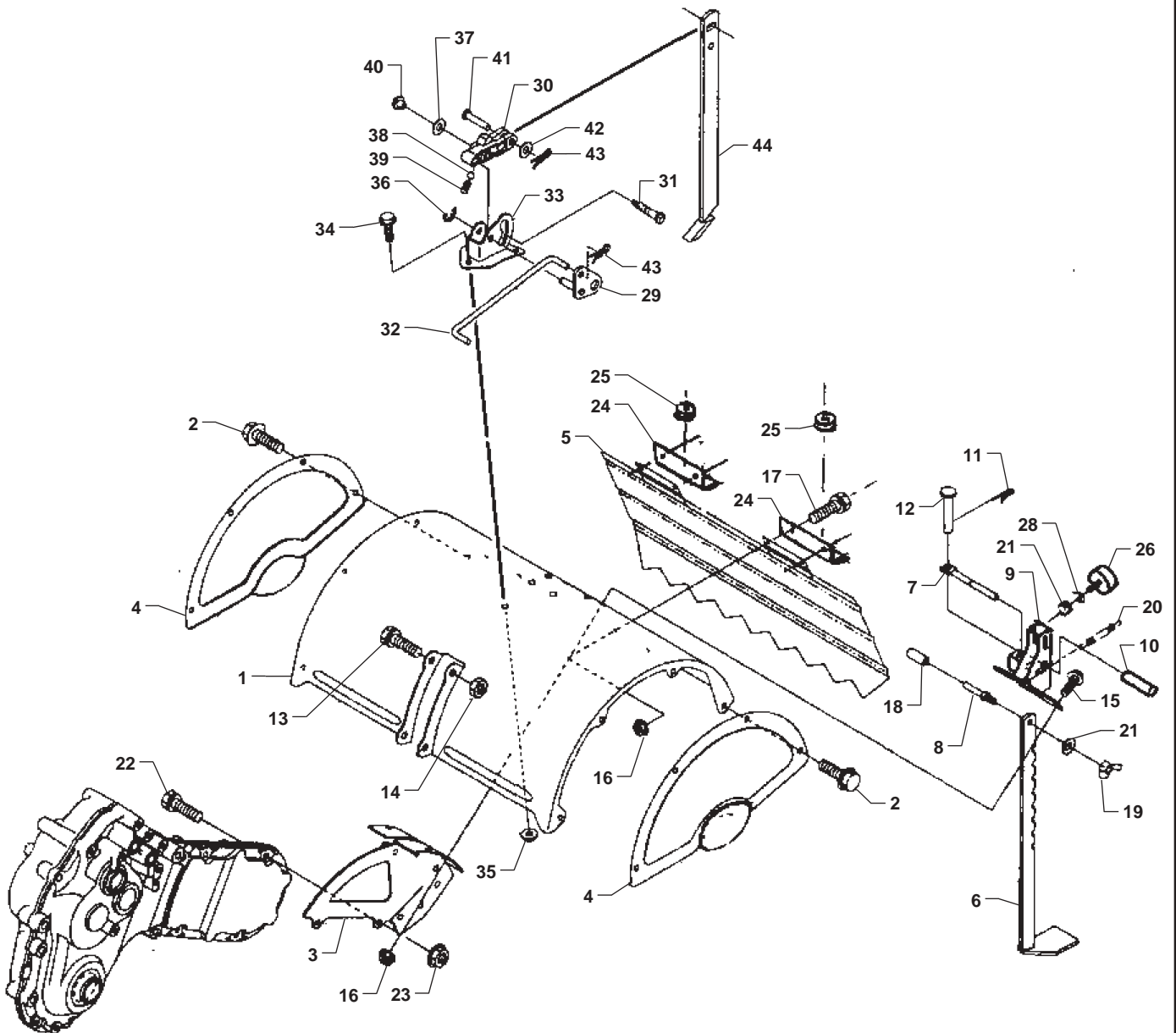

Rep N°	Ref.	Rq Rk	Désignation	Description	Qté Qty
1	P506 2201 000		CARTER DE ROTATION	ROTARY COVER	1
2	H114 0108 016		VIS M8x16	BOLT w/washer M8x16	8
3	1429 2202 001		PLAQUE SUPPORT	PLATE	1
4	P506 2204 000		CARTER DE CÔTÉ	COVER side	2
5	P506 2216 000		CARTER ARRIÈRE	COVER rear	1
6	1429 2224 000		BÉQUILLE	STAY B	1
7	1924 2228 000		LEVIER	LEVER	1
8	1924 2231 000		LEVIER	LEVER	1
9	1429 2231 000		SUPPORT	BRACKET	1
10	1421 2284 000		POIGNÉE	GRIP	1
11	0521 0106 000		GOUPILLE ø6	PIN snap ø6	1
12	0562 0108 035		AXE ø8 x 35	PIN clevis ø8 x 35	1
13	F050 0110 060		VIS M10x60	BOLT flange M10x60	2
14	F301 0110 000		ÉCROU M10	NUT flange M10	2
15	F050 0106 016		VIS M6x16	BOLT flange M6x16	4
16	F300 0106000		ÉCROU M6	NUT flange M6	8
17	F050 0106 012		VIS M6x12	BOLT flange M6x12	4
18	2786 0213 000		POIGNÉE	GRIP	1
19	A330 0100 800		ÉCROU M8	NUT wing M8	1
20	1429 2233 000		RESSORT	SPRING	1
21	A360 0100 802		RONDELLE RESSORT M8	WASHER spring M8	1
22	F050 0108 040		VIS M8x40	BOLT flange M8x40	2
23	F301 0108 000		ÉCROU M8	NUT flange M8	2
24	P506 2241 000		PLAQUE DE FIXATION	PLATE	2
25	P506 2243 000		BUTÉE CAOUTCHOUC	GROMET	2
26	3690 3643 000		MOLETTE	BOLT knob	1
27	1025 3308 100		RESSORT	SPRING	1
28	O350 0150 822		RONDELLE	WASHER	1
29	1429 2291 000		AXE	ARM	1
30	1429 2293 000		SUPPORT	ARM	1
31	1429 2294 000		AXE	PIN	1
32	1429 2296 000		BARRE	BAR	1
33	1429 2298 001		SUPPORT	BRACKET	1
34	F050 0106 012		VIS M6x12	BOLT flange M6x12	3
35	F300 0106 000		ÉCROU M6	NUT flange M6	3
36	O742 0100 800		CIRCLIPS ø8	E-RING ø8	2
37	O350 0140 618		RONDELLE M6	WASHER M6	1
38	O800 0000 600		BILLE 1/4"	BALL 1/4"	1
39	2717 2064 000		RESSORT	SPRING	1
40	2740 3129 000		POIGNÉE	GRIP	1
41	0562 1110 035		AXE ø10 x 35	PIN clevis ø10 x 35	1
42	0350 0141 022		RONDELLE M10	WASHER M10	1
43	0521 0108 000		GOUPILLE ø8	PIN snap ø8	2
44	1924 2219 000		BÉQUILLE	STAY A	1

ETIQUETTE / OUTIL MARK / TOOL

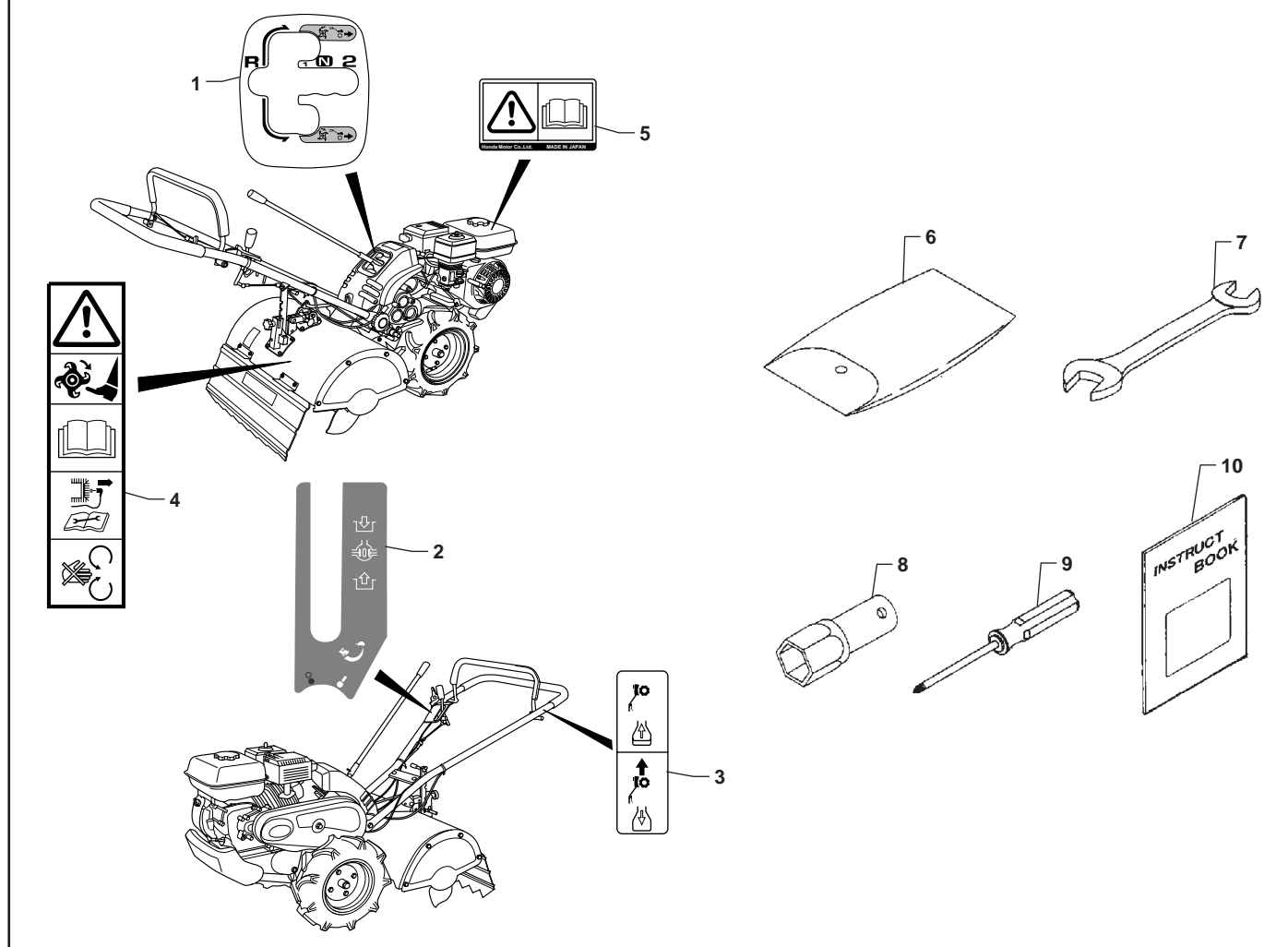

Rep N°	Ref.	Rq Rk	Désignation	Description	Qté Qty
1	P506 3010 000		Étiquette levier de vitesse	MARK sign	1
2	P506 3011 000		Étiquette embrayage de lame	MARK sign	1
3	P506 3012 000		Étiquette marche AV/AR	MARK sign	1
4	P506 3014 000		Étiquette attention	LABEL caution	1
5			Étiquette attention	LABEL caution	1
6	1428 2501 000		Sac	BAG	1
7	1428 2502 000		Clef de 10-12	SPANNAR 10X12	1
8	1428 2503 000		Clef	I-BOX WRENCH	1
9	1428 2504 000		Tournevis	DRIVER	1
10	1490 2701 000		Notice pièce de rechange	INSTRUCT BOOK	1